

A	Drawing updated	17.07.2014	RWd	-
Rev	Revision note	Date	Signature	Checked

General Notes:
1. Do not scale this drawing.

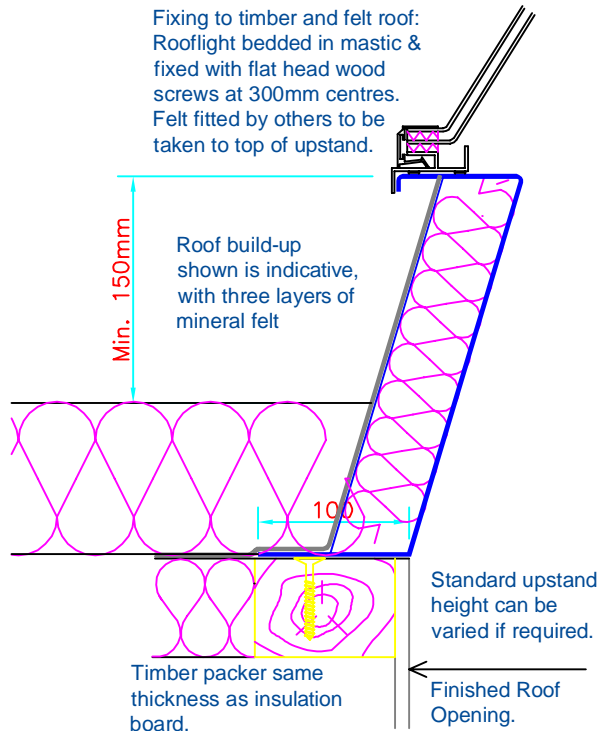

(For a 600x600 rooflight make finished hole size 600x600 etc.)

Fixing to timber and felt upstand:
Rooflight bedded in mastic and fixed with clutch head screws, 'sela' washers and caps at 300mm centres.

This rooflight can be made to fix internally. the hole opening must be accurate and an internal fixing specifically asked for.

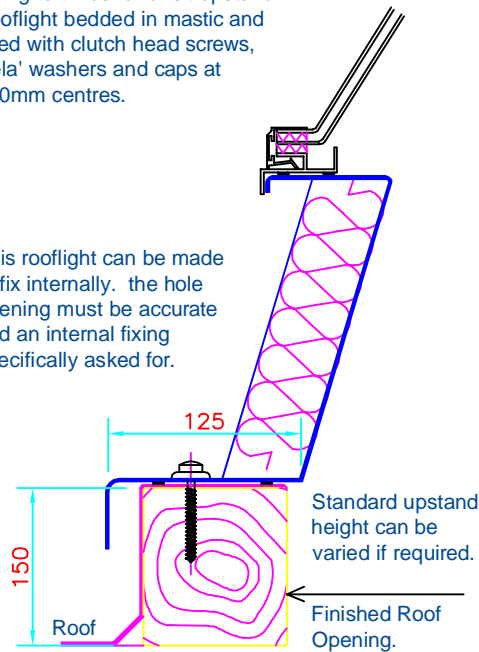

(For a 600x600 rooflight make finished hole size 600x600 etc.)

2. KERB ADAPTOR UPSTAND

Scale 1:5



LAREINE ENGINEERING LTD.

UNIT 1, ARMADALE INDUSTRIAL ESTATE.
ARMADALE EH48-2JY WEST LOTHIAN.
Tel 01501 731 800 Fax 01501 733 828

Title/Name

SOLUS NON VENTED ROOFLIGHT

Drawn

SY

Date

-

Scale

As
Shown

Drawing number

STD - 016

Rev